

An abstract graphic composed of numerous thin, light blue lines that curve and intersect to form a complex, wave-like structure. The lines are more densely packed in some areas, creating a mesh-like appearance, and more sparse in others, giving it a sense of depth and movement. It occupies the upper right portion of the page.

Transas AIS Receiver T-55

Product Manual



Thank you for buying this AIS receiver.

This product has been engineered to offer you the highest level of performance and durability and we hope that it will provide many years of reliable service. We constantly strive to achieve the highest possible quality standards. Should you encounter any problems with this product please contact your dealer who will be pleased to offer whatever assistance you require.

Table of contents

1	Notices	1
1.1	Safety warnings	1
1.2	General notices	1
2	About your AIS receiver	4
2.1	About AIS	4
2.2	What's in the box?	5
3	Installation	8
3.1	Preparing for installation	8
3.2	Installation procedures	9
4	Operation	17
4.1	Using the AIS receiver	17
4.2	Indicator functions	17
5	Troubleshooting	18
6	Specifications	19

Table of figures

Figure 1	Items included with the product.....	5
Figure 2	AIS receiver overview.....	6
Figure 3	Electrical connections to the AIS receiver	7
Figure 4	Typical installation	8
Figure 5	AIS receiver dimensions.....	10
Figure 6	AIS receiver mounting	11
Figure 7	Position of the VHF antenna connector.....	12
Figure 8	Colour coding of wires in the accessory cable.....	13
Figure 9	Connecting to the NMEA0183 data port.....	14
Figure 10	Connecting the power supply	16
Figure 11	Indicator location on the AIS receiver unit.....	17

1 Notices

 When reading this manual please pay attention to warnings marked with the warning triangle shown on the left. These are important messages for safety, installation and usage of the product.

1.1 Safety warnings

 This equipment must be installed in accordance with the instructions provided in this manual.

 This equipment is intended as an aid to navigation and is not a replacement for proper navigational judgement.

 This AIS receiver is an aid to navigation and must not be relied upon to provide accurate navigation information. AIS is not a replacement for vigilant human lookouts and other navigation aids such as RADAR. The performance of the AIS receiver may be seriously impaired if not installed as instructed in the user manual, or due to other factors such as weather and or nearby transmitting devices. Compatibility with other systems may vary and is reliant on the third party systems recognising the standard outputs from the AIS receiver. The manufacturer reserves the right to update and change these specifications at any time and without notice.

 Do not install this equipment in a flammable atmosphere such as in an engine room or near to fuel tanks.

1.2 General notices

Compass safe distance

The compass safe distance of this unit is 0.5m or greater for 0.3° deviation.

RF emissions notice

Caution: The AIS receiver generates and radiates radio frequency electromagnetic energy. This equipment must be installed and operated according to the instructions contained in this manual. Failure to do so can result in personal injury and / or AIS receiver malfunction.

Caution: The antenna should not be co-located or operated in conjunction with any other transmitting antenna. The required antenna impedance is 50Ω.

Warranty

The product is supplied with standard warranty as defined in the Warranty statement supplied with the product.

 **Changes or modifications to the product not expressly approved by the manufacturer could invalidate your authority to operate this radio equipment.**

FCC Notice

NOTE: This equipment has been tested and found to comply with the limits for a Class B digital device, pursuant to part 15 of the FCC Rules. These limits are designed to provide reasonable protection against harmful interference in a residential installation.

This equipment generates, uses and can radiate radio frequency energy and, if not installed and used in accordance with the instructions, may cause harmful interference to radio communications. However, there is no guarantee that interference will not occur in a particular installation. If this equipment does cause harmful interference to radio or television reception, which can be determined by turning the equipment off and on, the user is encouraged to try to correct the interference by one or more of the following measures:

- Reorient or relocate the receiving antenna.
- Increase the separation between the equipment and receiver.
- Connect the equipment into an outlet on a circuit different from that to which the receiver is connected.
- Consult the dealer or an experienced radio/TV technician for help.

This device complies with part 15 of the FCC Rules. Operation is subject to the following two conditions:

1. This device may not cause harmful interference, and
2. This device must accept any interference received, including interference that may cause undesired operation.

Industry Canada Notice

This device complies with Industry Canada licence-exempt RSS standard(s). Operation is subject to the following two conditions:

1. This device may not cause interference, and
2. This device must accept any interference, including interference that may cause undesired operation of the device.

This Class B digital apparatus complies with Canadian ICES-003.

Le présent appareil est conforme aux CNR d'Industrie Canada applicables aux appareils radio exempts de licence. L'exploitation est autorisée aux deux conditions suivantes :

1. L'appareil ne doit pas produire de brouillage, et
2. L'utilisateur de l'appareil doit accepter tout brouillage radioélectrique subi, même si le brouillage est susceptible d'en compromettre le fonctionnement.

Cet appareil numérique de la classe B est conforme à la norme NMB-003 du Canada.

Disposal of this product and packaging

Please dispose of the AIS receiver in accordance with the European WEEE Directive or with the applicable local regulations for disposal of electrical equipment.

Every effort has been made to ensure the packaging for this product is recyclable. Please dispose of the packaging in an environmentally friendly manner.

Accuracy of this manual

The AIS receiver may be upgraded from time to time and future versions of the AIS receiver may therefore not correspond exactly with this manual. The manufacturer of this product disclaims any liability for consequences arising from omissions or inaccuracies in this manual and any other documentation provided with this product.

2 About your AIS receiver

2.1 About AIS

The marine Automatic Identification System (AIS) is a location and vessel information reporting system. It allows vessels equipped with AIS to automatically and dynamically share and regularly update their position, speed, course and other information such as vessel identity with similarly equipped vessels. Position is derived from the Global Positioning System (GPS) and communication between vessels is by Very High Frequency (VHF) digital transmissions.

There are a number of types of AIS device as follows:

- **Class A transceivers.** These are similar to class B transceivers, but are designed to be fitted to large vessels such as cargo ships and large passenger vessels. Class A transceivers transmit at a higher VHF signal power than class B transceivers and therefore can be received by more distant vessels. They also transmit more frequently. Class A transceivers are mandatory on all vessels over 300 gross tonnes on international voyages and certain types of passenger vessels under SOLAS regulations.
- **Class B transceivers.** Similar to class A transceivers in many ways, but are normally lower cost due to the less stringent performance requirements. Class B transceivers transmit at a lower power and at a lower reporting rate than class A transceivers.
- **AIS base stations.** AIS base stations are used by Vessel Traffic Systems to monitor and control the transmissions of AIS transceivers.
- **Aids to Navigation (AtoN) transceivers.** AtoNs are transceivers mounted on buoys or other hazards to shipping which transmit details of their location to the surrounding vessels.
- **AIS receivers.** AIS receivers will generally receive transmissions from class A transceivers, class B transceivers, AtoNs and AIS base stations but do not transmit any information about the vessel on which they are installed.

This product is an AIS receiver.

2.2 What's in the box?

Figure 1 shows the items included with your AIS receiver purchase. The following sections give a brief overview of each item. Please ensure all items are present and if any of the items are not present contact your dealer.

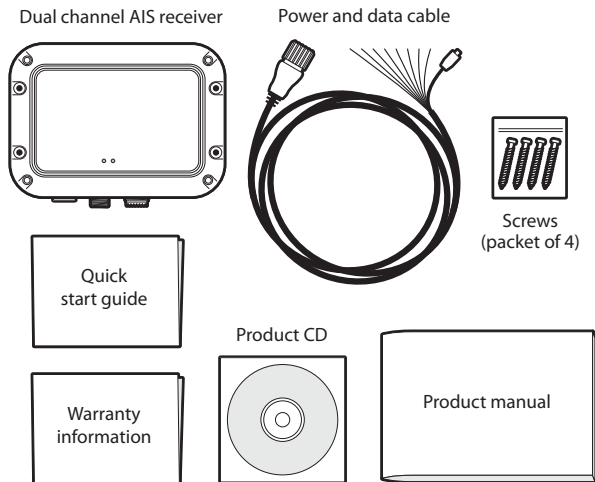

Figure 1 Items included with the product

- Support tools CD

The CD supplied with the package contains the USB drivers to enable use of the AIS receiver via its USB interface. Also included on the CD is the product manual in other languages.

- Quick start guide

The quick start guide gives a handy one page reference for the installation process.

- Product manual

This document is the product manual and should be read thoroughly prior to any attempt to install or use the AIS receiver.

- Fixing screws

Four fixing screws are provided with the product for mounting of the AIS receiver. Please refer to section 3.2 for details of how to mount the AIS receiver.

- AIS receiver unit

Figure 2 shows an overview of the AIS receiver unit.

The AIS receiver has an indicator which provides information to the user about the status of the AIS receiver. Please refer to section 4.2 for more details of the indicator functions.

- Power and data cable

The accessory cable provides connections to the AIS receiver for power supply, NMEA0183 and USB.

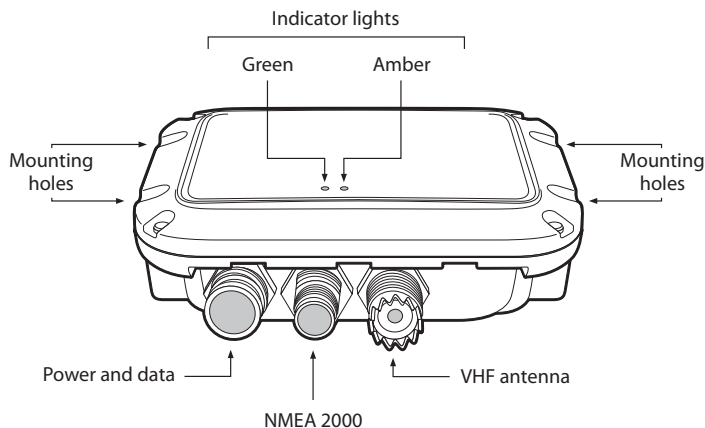

Figure 2 AIS receiver overview

Electrical connections

The AIS receiver has the following electrical connections:

- Power supply
- NMEA0183 data port for connection to chart plotters
- USB for connection to a PC or Mac
- NMEA2000 port for connection to NMEA2000 compatible equipment

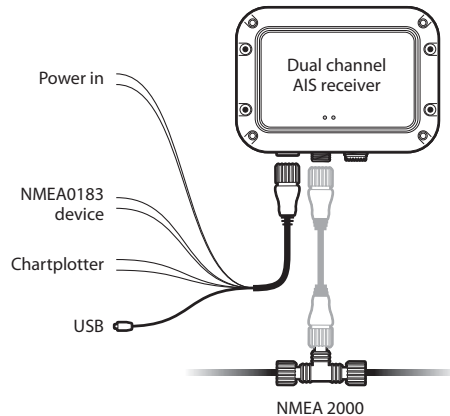

Figure 3 Electrical connections to the AIS receiver

3 Installation

3.1 Preparing for installation

Figure 4 shows a typical installation configuration for the AIS receiver. Please take the time to familiarise yourself with the system elements and their connections prior to attempting installation.

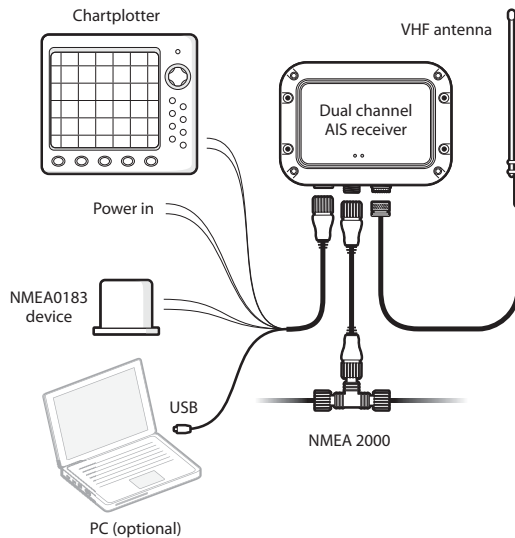

Figure 4 Typical installation

In addition to the items provided with your AIS receiver the following items will be required for installation:

VHF antenna

Connection to a suitable VHF antenna will be required for the AIS receiver to operate. A standard marine band VHF antenna such as that used with VHF voice radios will be sufficient. Please take note of the warnings in section 1 regarding the use of antennas.

Alternatively, if you wish to use an existing VHF antenna, antenna splitter products are available which allow the existing antenna to be used with two radio devices, such as a VHF voice radio and the AIS receiver.

Antenna cables

Please check that the VHF antenna you intend to use has sufficient cable to reach between the VHF antenna and the AIS receiver unit. If it is not sufficient you will need an extension cable. Please contact your dealer for details of suitable products. For reference the VHF antenna connector type on the AIS receiver unit is SO239, and is intended to mate with a PL259 connector.

Power and data cables

The AIS receiver unit is supplied with a two metre long power and data cable the AIS receiver unit is supplied with a two meter long power and data cable. If you require longer cables to reach your power supply, please ensure the cables are capable of carrying an average current of up to 200mA. Means of connecting the cables together will also be required. The use of Scotchlok™ connectors is recommended for this purpose.

Chart plotter

To display received AIS position reports as other vessels on your chart plotter, you will need to connect your AIS receiver to your chart plotter. Please refer to the user manual supplied with your chart plotter for details of how to connect and configure your chart plotter for use with AIS devices. For general guidance your chart plotter should be configured to accept NMEA data at 38400 baud (sometimes referred to as 'NMEA HS' in the plotter configuration menu). You may also need to enable the display of AIS targets in the chart options.

Connection to a PC or Mac

If you choose to use a PC or Mac with suitable charting software to display received AIS messages as other vessels, this can be accomplished by connecting the USB connector directly to the PC or Mac. Your PC may require USB software drivers to connect to the AIS receiver and these can be found on the CD included with the product.

3.2 Installation procedures

Before beginning installation of your AIS receiver, please ensure you have the necessary additional items as detailed in section 3.1. It is strongly recommended that you read all of the instructions in this manual prior to installation.

If after reading this manual you are unsure about any element of the installation process please contact your dealer for advice.

The following sections explain the installation process step by step for each of the main elements of the system.

Step 1 - Installing the AIS receiver

Please note the following guidelines when selecting a location for your AIS receiver:

- The AIS receiver must be fitted in a location where it is at least 0.5m from a compass.

- There should be adequate space around the AIS receiver for routing of cables. See Figure 5 for details of the AIS receiver dimensions.
- The ambient temperature around the AIS receiver should be maintained between -25°C and $+55^{\circ}\text{C}$.
- The AIS receiver should not be located in a flammable or hazardous atmosphere such as in an engine room or near to fuel tanks.
- The AIS receiver is fully waterproof to ingress protection rating IPx7, however it is recommended that the AIS receiver is not subjected to extended periods of exposure to spray or submersion.
- It is recommended that the AIS receiver is installed in a 'below decks' environment.
- It is acceptable to mount the AIS receiver either vertically or horizontally.
- The product is supplied with four self tapping screws for attachment of the AIS receiver to a suitable surface. Please refer to Figure 6 for guidance.
- The AIS receiver should be mounted in a location where the indicator is readily visible as this provides important information on the status of the AIS receiver.

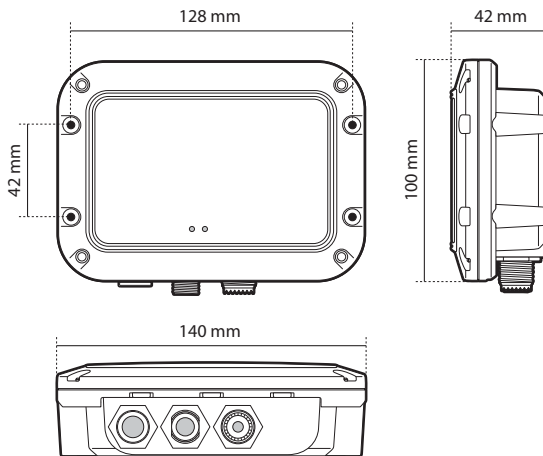

Figure 5 AIS receiver dimensions

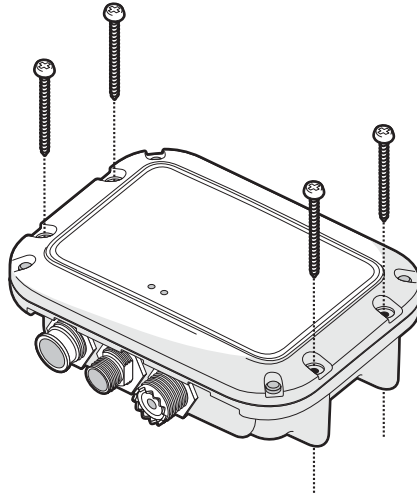

Figure 6 AIS receiver mounting

Step 2 - Connecting the VHF antenna

Route the cable from the VHF antenna to the AIS receiver and connect to the VHF connector on the AIS receiver as shown in Figure 7. A standard marine band VHF antenna or AIS antenna should be used with the AIS receiver. The connector type on the AIS receiver is SO239. Your chosen VHF antenna requires a PL259 connector to mate with this. If your VHF antenna does not use this type of connector please contact your dealer for details of available adaptors.

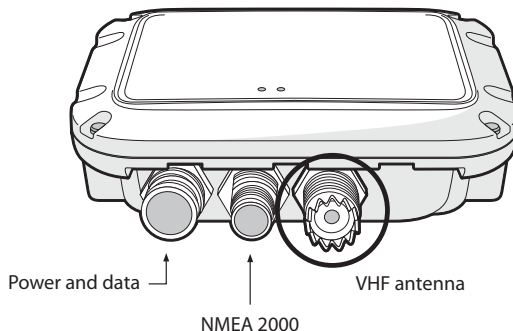

Figure 7 Position of the VHF antenna connector

Step 3 - Connecting the accessory cable

An accessory cable is supplied with the product to provide connections to power, the NMEA0183 data ports and USB. The cable has a pre-moulded connector at one end which should be connected to the connector on the unit marked 'PWR/DATA'. The other end of the cable has eight colour coded bare wires ready for connection and a USB connector for use with a PC. The table below in Figure 8 lists the function of each colour coded wire for reference.

Wire colour	Description	Function
Red	Power in +	Power supply connections
Black	Power in -	
Green	Not used	No connection
Orange	Not used	
Brown	NMEA0183 port 1 TX+	High speed NMEA0183 port (38,400baud) intended for connection to chart plotters
Blue	NMEA0183 port 1 TX-	
Purple	NMEA0183 port 2 RX+	Low speed NMEA port (4,800baud) intended for connection to other NMEA0183 compatible sensors for multiplexing of data to the chart plotter
Yellow	NMEA0183 port 2 RX-	

Figure 8 Colour coding of wires in the accessory cable



Please check your wiring very carefully before applying power to the product. Failure to wire the product correctly could result in permanent damage.

Step 4 - Connecting to NMEA0183 compatible equipment

The two independent NMEA0183 data ports provide connection to your chart plotter and other NMEA0183 compatible equipment. Each port consists of two wires colour coded as shown in the table in Figure 8 and in the diagram in Figure 9. Connect the wires to the appropriate connections on your NMEA0183 compatible equipment. Please refer to your equipment manual for more information.

The AIS receiver has a high speed output port which operates at 38,400baud and a low speed input port which operates at 4,800baud. The high speed port is intended primarily to connect to a chart plotter, while the low speed port is intended to connect to other NMEA0183 devices. A multiplexing feature is provided, which means any messages which are received via the low speed port are automatically transmitted via the high speed port. This is particularly useful when using a chart plotter having only a single NMEA0183 port as any other sensor (such as a gyro-compass) can be connected to the AIS receiver via the low speed port and the AIS receiver can be connected via the high speed port to the chart plotter resulting in the chart plotter receiving both AIS information and heading information simultaneously. Please ensure your equipment is configured to use the correct baud rate for the port it is connected to.

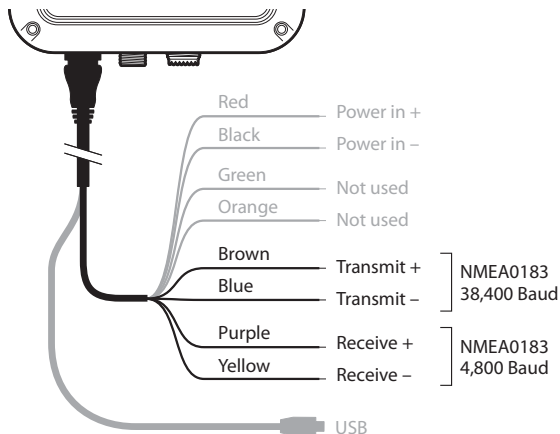

Figure 9 Connecting to the NMEA0183 data port

Step 5 - Connection to an NMEA2000 network (optional)

The AIS receiver can be connected to an NMEA2000 network by a suitable NMEA2000 network cable available from your local dealer. If your vessel has an NMEA2000 network please refer to the relevant documentation for your NMEA2000 equipment. Once connected, and with your chart plotter also connected to your NMEA2000 network you will be able to receive AIS targets on your chart plotter.

Step 6 - USB Connection (optional)

The AIS receiver is supplied with a USB port for connection to a PC or Mac. The USB connector can be connected directly to the USB port on the PC or Mac via the supplied USB cable. To enable connection of the AIS receiver to a PC the USB drivers, supplied on the product CD, must first be installed on the PC. Driver installation is typically not required for use with a Mac.

To install the drivers please follows the steps below:

1. Insert the product CD into the PC and navigate to the USB drivers folder.
2. Double click on the setup.exe file to launch the installer.
3. Follow the on screen installation instructions to complete installation.
4. Once installed the AIS unit can be connected to the PC. The USB drivers will be installed automatically and the AIS will appear as a new COM port device.
5. Select the AIS COM port and a baud rate of 38,400 in PC based navigation software to make use of the AIS data.



If the USB connection is removed from the PC or Mac during use you must reset the connection before further use. To reset the connection, disconnect then reapply power to the AIS before closing and relaunching any PC or Mac applications using the USB connection. Finally, reconnect the USB cable between the PC or Mac and the AIS receiver.

Step 7 - Connecting to a power supply

The AIS receiver requires either a 12V or 24V power supply typically provided by the vessel's battery, or it can be powered via USB.

It is recommended that crimped and soldered lugs are used to connect the AIS receiver to the power source. It is recommended that the power supply is connected via a suitable circuit breaker and/or 3A fuse block.

1. Connect the **red** wire to a 12V or 24V power supply positive terminal.
2. Connect the **black** wire to the supply negative terminal.

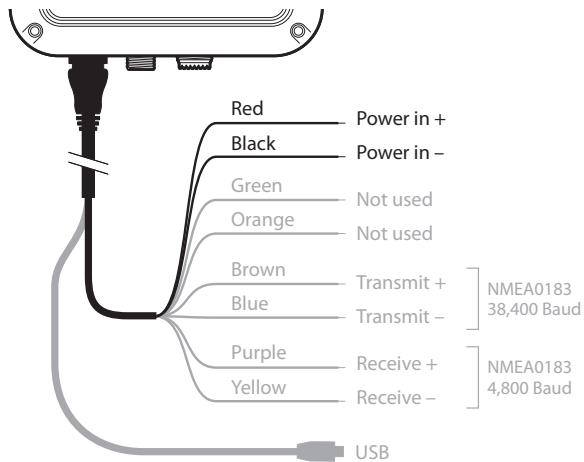

Figure 10 Connecting the power supply

4 Operation

4.1 Using the AIS receiver

Once the unit has been installed it is ready for use. Providing other vessels with AIS transceivers installed are within radio range of your vessel you should see their details appear on your chart plotter or PC.

Specific details of how to configure your chart plotter to make use of the AIS receiver features will be given in your chart plotter manual. If you are using charting software running on a PC, please refer to the instructions provided with your chart plotting software for details of how to configure it to display AIS information.

4.2 Indicator functions

The AIS receiver includes a green power indicator light and an amber AIS reception indicator light as shown in Figure 11. The green indicator will illuminate when power is applied and the amber indicator will flash on receipt of AIS messages.

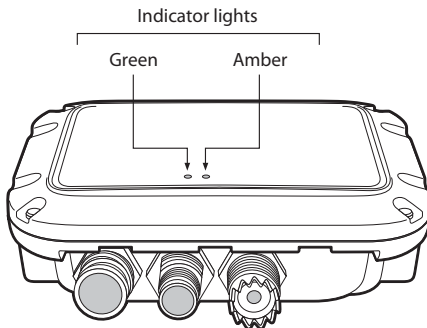

Figure 11 Indicator location on the AIS receiver unit

5 Troubleshooting

Issue	Possible cause and remedy
No data is being received by the chart plotter	<ul style="list-style-type: none"> • Check that the power supply is connected correctly. • Check that the connections to the chart plotter are correct. • Check that the VHF antenna is correctly connected in accordance with the instructions in the manual
The power indicator is not illuminated	<ul style="list-style-type: none"> • Check that the power supply is connected correctly.
The reception indicator is flashing but AIS targets are not displayed on the chart plotter	<ul style="list-style-type: none"> • Check the chart plotter NMEA port configuration is set to receive AIS data • Check the chart plotter display settings are configured to show AIS targets • Consult the chart plotter manufacturers documentation
The power indicator is illuminated but the reception indicator is not flashing to indicate receipt of AIS messages	<ul style="list-style-type: none"> • Check there are vessels equipped with AIS transceivers in your area • Check the VHF antenna is correctly installed and connected

If the guidance given in the table above does not rectify the problem you are experiencing, please contact your dealer for further assistance.

6 Specifications

Parameter	Value
Dimensions	140 x 100 x 42 mm (L x W x H)
Weight	250g (AIS receiver unit only)
Power	DC (9.6 - 31.2V) or USB powered
	Average power consumption <1W
	Current consumption <200mA at 12VDC
Electrical interfaces	USB NMEA0183 38,400 baud output NMEA0183 4,800 baud input NMEA2000 LEN=1
Connectors	VHF antenna connector (SO-239) USB type A plug NMEA2000 standard connector 12 way power input / NMEA0183
Dual channel receiver	Fixed frequency reception at 161.975MHz and 162.025MHz
Channel Bandwidth	25kHz
Receiver Sensitivity	Better than -112dBm at 20% Packet Error Rate
Environmental	Operating temperature: -25°C to +55°C
Ingress Protection rating	IPx7

